

Attention
Reverse Threaded
For Tamper Proof Purposes

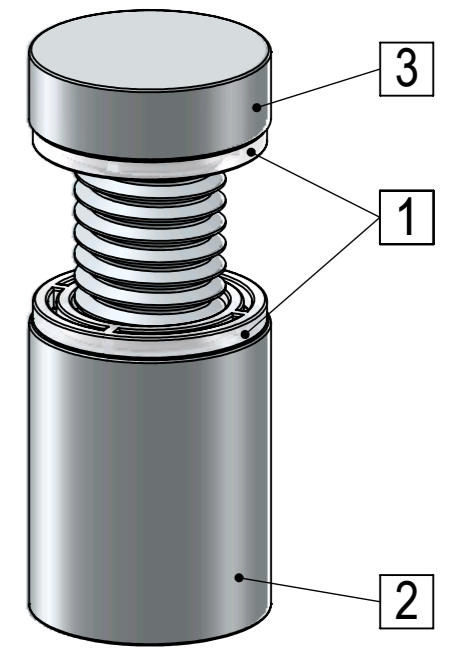

SECTION E-E
SCALE 2 : 1
M10 Thread

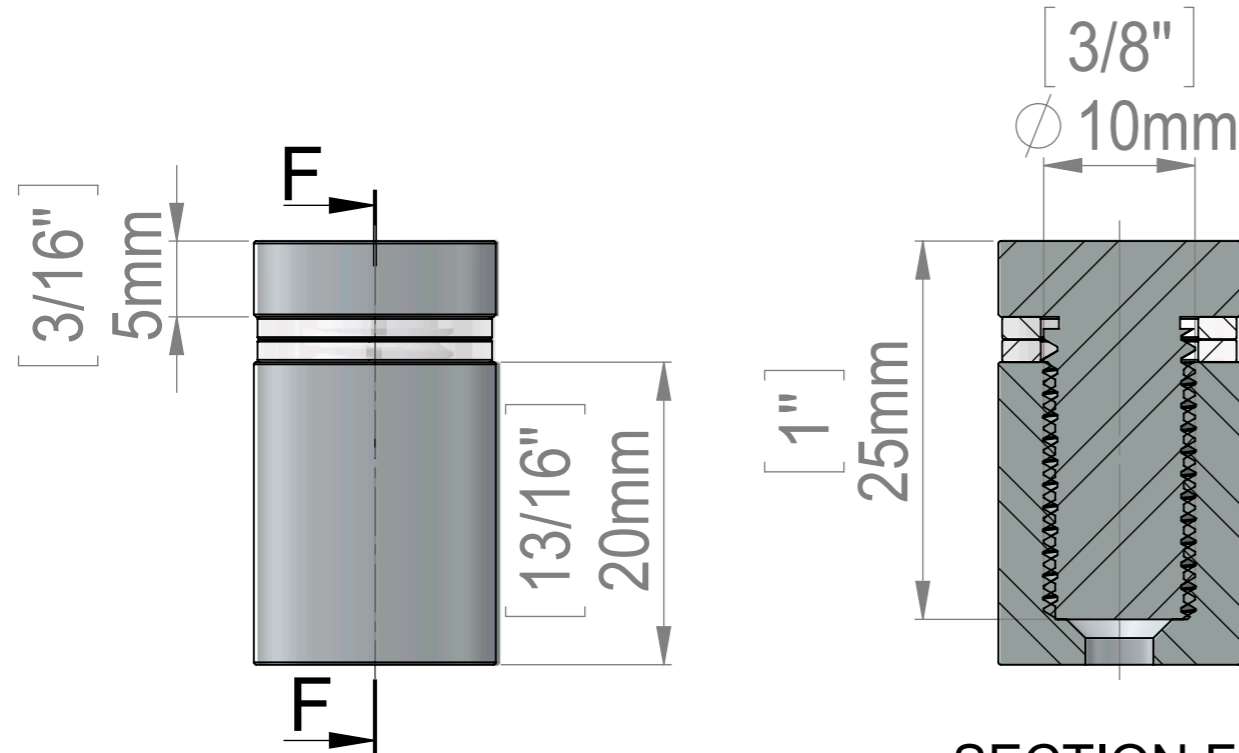

SECTION F-F
SCALE 2 : 1



ITEM NO.	PART NUMBER	DESCRIPTION	QTY.
1	FAH16_Washer		2
2	FAH16-25_Body-16x20-Reverse_Thread		1
3	HM1107A(FHA16-25)-Reverse_Thread		1

Title : FAH16-25		Scale : 2:1		Mbs R&D	
		Sizes : Letter Landscape		Customer:	
Material:		Finish		Qty :	Rep :
N°programme laser		N°prog. Mécanum.		N° Plan : FAH16-25	