

1/8 Hex Female Standoff

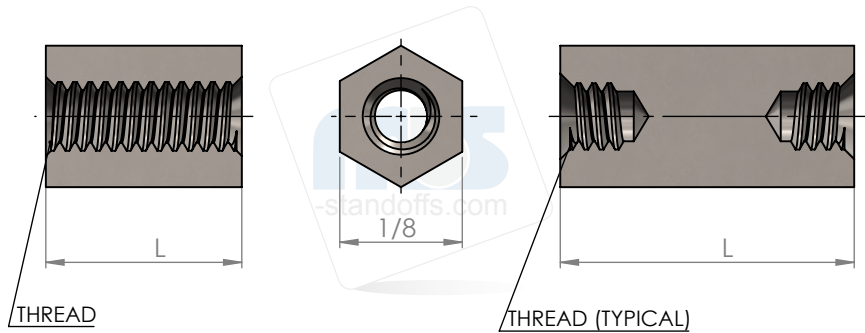

Create a part number:

Length	Thread	Material	Finish
FCXXXX	XXX	XX	XX
_____ - _____ - _____ - _____			

Hex Code Table	
FCXXXX	Length (L)
FC2020	1/8
FC2021	3/16
FC2022	1/4
FC2023	5/16
FC2024	3/8
FC2025	7/16
FC2026	1/2
FC2027	9/16
FC2028	5/8
FC2029	11/16
FC2030	3/4
FC2031	13/16
FC2032	7/8
FC2033	15/16
FC2034	1
FC2035	1-1/16
FC2036	1-1/8
FC2037	1-3/16
FC2038	1-1/4
FC2039	1-5/16
FC2040	1-3/8
FC2041	1-7/16
FC2142	1-1/2
FC2143	1-9/16
FC2144	1-5/8
FC2145	1-11/16
FC2146	1-3/4
FC2147	1-13/16
FC2148	1-7/8
FC2149	1-15/16
FC2150	2

Thread			
Thread Code (XXX)	Tapped Thru		Longer Parts
	A, B, S	SS	Blind Tap Depth
080	3/8	1/4	3/16
256	3/4	5/8	3/16

Aluminum (A), Brass (B), Steel (S), Stainless Steel (SS)

Material	
Material Code (XX)	
A	Aluminum
B	Brass
S	Steel
SS	Stainless Steel
N	Nylon

Tolerances Unless otherwise Specified
 .xxx +/- .005
 .xx +/- .010
 Angular +/- 1 Degree
 Linear +/- .005
Break all sharp edges

Compatible Finish	
A, B, S, SS	0 - Plain
B, S	5 - Nickel Plate (QQ-N-290)
A	6 - Iridite #14 Gold (MIL-C-5541E)
A	7 - Iridite Clear (MIL-C-5541E)
A	9 - Alodine 1200
B, S	12 - Zinc Clear (ASTM-B-633)
B, S	16 - Electro Tin (MIL-T-10727 TYPE 1)
SS	20 - Passivation (MIL-F-14072D)
A	22 - Clear Anodize (MIL-A-8625-TYPE2) (Sulphuric) Hot Water Seal (Clear)
A	24 - Black Anodize (MIL-A-8625)
B, S, SS	26 - Black Oxide
B, S	28 - Zinc Yellow (ASTM-B-633)



5046 W Linebaugh Ave
 Tampa, FL, 33624
 sales@mbs-standoffs.com
 Mbs-Standoffs.com
 P: (813) 938-6025
 F: (813) 425-9007

Source Control Drawing:
 To be produced by
 mbs-standoffs

This document is the property of mbs-standoffs Inc. and shall not be reproduced, distributed, or used as a basis for manufacturing without written permission from mbs-standoffs Inc.