

Hex Code Table		
✓ FCXXXX	Length (L)	
FC1678	1/8	
FC1679	3/16	
FC1680	1/4	
FC1681	5/16	
FC1682	3/8	
FC1683	7/16	
FC1684	1/2	
FC1685	9/16	
FC1686	5/8	
FC1687	11/16	
FC1688	3/4	
FC1689	13/16	
FC1690	7/8	
FC1691	15/16	
FC1692	1	
FC1693	1-1/16	
FC1694	1-1/8	
FC1695	1-3/16	
FC1696	1-1/4	
FC1697	1-5/16	
FC1698	1-3/8	
FC1699	1-7/16	
FC1700	1-1/2	
FC1701	1-9/16	
FC1702	1-5/8	
FC1703	1-11/16	
FC1704	1-3/4	
FC1705	1-13/16	
FC1706	1-7/8	
FC1707	1-15/16	
FC1708	2	
FC1709	2-1/8	
FC1710	2-1/4	
FC1711	2-3/8	
FC1712	2-1/2	
FC1713	2-5/8	
FC1714	2-3/4	
FC1715	2-7/8	
FC1716	3	
FC1717	3-1/4	
FC1718	3-1/2	
FC1719	3-3/4	
FC1720	4	
FC1721	4-1/4	
FC1722	4-1/2	
FC1723	4-3/4	
FC1724	5	
FC1725	5-1/4	
FC1726	5-1/2	
FC1727	5-3/4	
FC1728	6	

1/4 Round Female Standoff

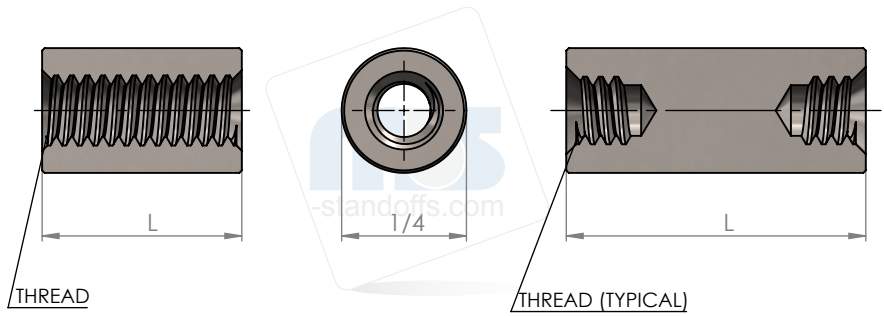

Create a part number:

Length	Thread	Material	Finish
FCXXXX	XXX	XX	XX
_____ - _____ - _____ - _____			

✓	Thread			
	Thread Code (XXX)	Tapped Thru		Longer Parts
		A, B, S	SS	Blind Tap Depth
	440	1	3/4	1/4
	632	1	1	3/8
	832	1	1	7/16
	1032	1-1/8	1	1/2

Aluminum (A), Brass (B), Steel (S), Stainless Steel (SS)

✓	Material	
	Material Code (XX)	
	A	Aluminum
	B	Brass
	S	Steel
	SS	Stainless Steel
	N	Nylon

Tolerances Unless otherwise Specified
 .xxx +/- .005
 .xx +/- .010
 Angular +/- 1 Degree
 Linear +/- .005
Break all sharp edges

✓	Compatible Finish	
	A, B, S, SS	0 - Plain
	B, S	5 - Nickel Plate (QQ-N-290)
	A	6 - Iridite #14 Gold (MIL-C-5541E)
	A	7 - Iridite Clear (MIL-C-5541E)
	A	9 - Alodine 1200
	B, S	12 - Zinc Clear (ASTM-B-633)
	B, S	16 - Electro Tin (MIL-T-10727 TYPE 1)
	SS	20 - Passivation (MIL-F-14072D)
	A	22 - Clear Anodize (MIL-A-8625-TYPE2) (Sulphuric) Hot Water Seal (Clear)
	A	24 - Black Anodize (MIL-A-8625)
	B, S, SS	26 - Black Oxide
	B, S	28 - Zinc Yellow (ASTM-B-633)



5046 W Linebaugh Ave
 Tampa, FL, 33624
 sales@mbs-standoffs.com
 Mbs-Standoffs.com
 P: (813) 938-6025
 F: (813) 425-9007

Source Control Drawing:
 To be produced by
 mbs-standoffs

This document is the property of mbs-standoffs Inc. and shall not be reproduced, distributed, or used as a basis for manufacturing without written permission from mbs-standoffs Inc.