

Hex Length Table	
FCXXXX	Length (L)
FC4669	1/4
FC4670	5/16
FC4671	3/8
FC4672	7/16
FC4673	1/2
FC4674	9/16
FC4675	5/8
FC4676	11/16
FC4677	3/4
FC4678	13/16
FC4679	7/8
FC4680	15/16
FC4681	1
FC4682	1-1/16
FC4683	1-1/8
FC4684	1-3/16
FC4685	1-1/4
FC4686	1-5/16
FC4687	1-3/8
FC4688	1-7/16
FC4689	1-1/2
FC4690	1-9/16
FC4691	1-5/8
FC4692	1-11/16
FC4693	1-3/4
FC4694	1-13/16
FC4695	1-7/8
FC4696	1-15/16
FC4697	2
FC4698	2-1/8
FC4699	2-1/4
FC4700	2-3/8
FC4701	2-1/2
FC4702	2-5/8
FC4703	2-3/4
FC4704	2-7/8
FC4705	3
FC4706	3-1/4
FC4707	3-1/2
FC4708	3-3/4
FC4709	4
FC4710	4-1/4
FC4711	4-1/2
FC4712	4-3/4
FC4713	5
FC4714	5-1/4
FC4715	5-1/2
FC4716	5-3/4
FC4717	6

## 1/2 Hex Male-Female Standoff

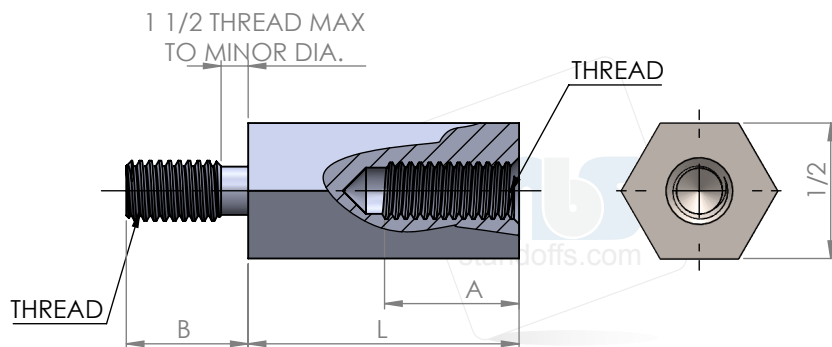

### Create a part number:

Length	Thread	Material	Finish
FCXXXX	XXX	XX	XX
_____ - _____ - _____ - _____			

Thread			
Short lengths, 'A' tapped to maximum depth			
Thread Code (XXX)	Depth (A)	Length (B)	
1032	1/2	3/8	
1224	1/2	3/8	
2520	5/8	1/2	
3118	5/8	1/2	

Material		
Material Code (XX)		
A	Aluminum	
B	Brass	
S	Steel	
SS	Stainless Steel	
N	Nylon	

**Tolerances Unless otherwise Specified**  
 .xxx +/--.005  
 .xx +/--.010  
 Angular +/- 1 Degree  
 Linear +/--.005  
**Break all sharp edges**

Compatible Finish	
A, B, S, SS	0 - Plain
B, S	5 - Nickel Plate (QQ-N-290)
A	6 - Iridite #14 Gold (MIL-C-5541E)
A	7 - Iridite Clear (MIL-C-5541E)
A	9 - Alodine 1200
B, S	12 - Zinc Clear (ASTM-B-633)
B, S	16 - Electro Tin (MIL-T-10727 TYPE 1)
SS	20 - Passivation (MIL-F-14072D)
A	22 - Clear Anodize (MIL-A-8625-TYPE2) (Sulphuric) Hot Water Seal (Clear)
A	24 - Black Anodize (MIL-A-8625)
B, S, SS	26 - Black Oxide
B, S	28 - Zinc Yellow (ASTM-B-633)



5046 W Linebaugh Ave  
 Tampa, FL, 33624  
 sales@mbs-standoffs.com  
 Mbs-Standoffs.com  
 P: (813) 938-6025  
 F: (813) 425-9007

Source Control Drawing:  
 To be produced by  
 mbs-standoffs

This document is the property of mbs-standoffs Inc. and shall not be reproduced, distributed, or used as a basis for manufacturing without written permission from mbs-standoffs Inc.